

# KISSLING BI-STABLE RELAYS WITH INTERNAL CONTROL ELECTRONICS

## Series 31 / ENERGY

Our series 31 bi-stable power relay with internal control electronics is based on the Series 30 industrial relay and has all the same quality mechanical and electrical switching characteristics - but also features additional electronic functions.

This relay is particularly well suited for battery management and power distribution applications on commercial vehicles, buses, construction & agricultural vehicles, aircraft, ground support equipment and lift trucks.

Our robust design of our bi-stable relays provide a sealing rate of IP67 and IP6K9K (steam pressure cleaning) in accordance with IEC 60529 and DIN 40050-9. The series 31 includes power relays in nominal voltages of 12 & 24 V and nominal continuous amperages of 300 A. Contact voltages up to 250 VDC with magential blowout (>40 VDC).

### Electronic energy storage-control

The relay has only two control connections which make it possible to replace a standard monostable relay with a bi-stable relay providing the advantage of powerless holding.

The internal capacitor is charged during the switch-on process. When the power supply is removed, the capacitor discharges the power into the drop out coil, which therefore switches off the relay. The characteristics of a standard bi-stable relay requires resupply of energy to drop out the coil. The electronics are short-circuit protected and feature safety coil selection, reverse polarity protection and coil cancellation.

### KEY BENEFITS

- Sealed housing meets IP67 and IP6K9K
- Robust design
- Variety of configuration options
- 6G shock and 4G vibration resistant
- “Energy” function for automatic shutoff in case of loss of power improves safety levels and reaction times in critical situations

### APPLICATIONS

- Commercial vehicles
- Bus
- Lift truck
- Ground support equipment
- Construction and agricultural vehicles

## CIRCUITS

NO-Contact  
Standard type

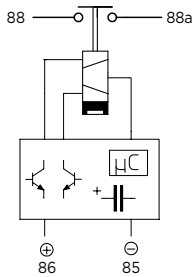

NO-Contact Plugin connection /  
Magnetic blowout

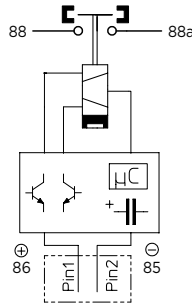

## SPECIFICATION

Technical Data	
Temperature range	-40°C to +85°C
Protection	IEC 60529 & DIN 40050-9 - IP67 (0,2 bar, 1 min) and IP6K9K
Shock	6g / 11 msec
Vibration	4g / 50 - 2000 Hz
Thread sizes / Torque	M4 = 2.0 - 2.2 Nm   M10 = 15 - 20 Nm

Electrical Characteristics	
Min. Insulation resistance	100 MΩ
After live or environment	50 MΩ
Dielectric withstanding voltage	1050 VAC / 1 min at 50 Hz
Max. Contact drop, initial	150 mV
Contact drop after life test	175 mV
Continuous current	300 A
Overload	2400 A - 1 sec / 600 A - 20 sec
Quiescent current	Approx. 2 mA

Rated contact load	
Resistive load	50,000 cycles 300 A
Mechanical life	100,000 cycles

# KISSLING BI-STABLE RELAYS WITH INTERNAL CONTROL ELECTRONICS

Series 31 / ENERGY

Coil Data	12 VDC	24 / 28 VDC
Voltage range	9-16 VDC	18-32 VDC
Nominal voltage	12 VDC	28 VDC
Pick up voltage max.	2.1 $\Omega \pm 20\%$	7.8 $\Omega \pm 20\%$
Drop out voltage min.	2.6 $\Omega \pm 20\%$	8.4 $\Omega \pm 20\%$

Operating times	
Min. pick up time	approx. 500 msec
Bounce time	max. 5 msec
Min. drop time	approx. 100 msec
Wire Section	min. 95 mm <sup>2</sup> / 0.147 sq.inch / AWG 4-0
Mounting position	Optional

## TECHNICAL DRAWINGS

Standard side mounting

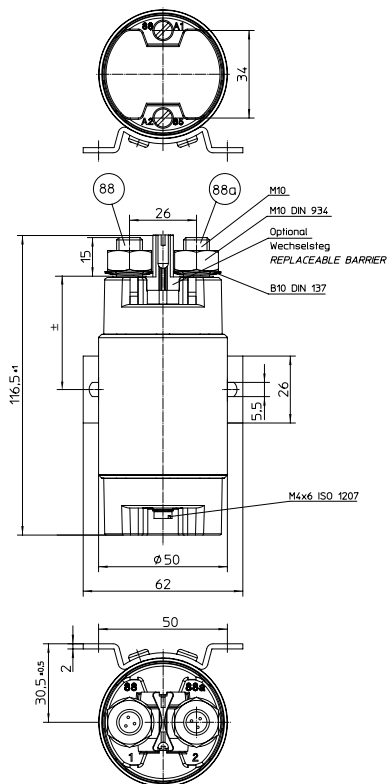

Short form side mounting

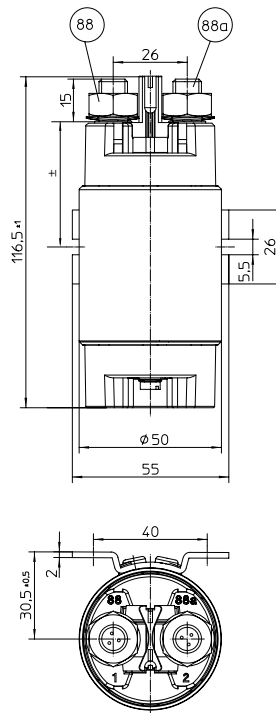

Short form side mounting

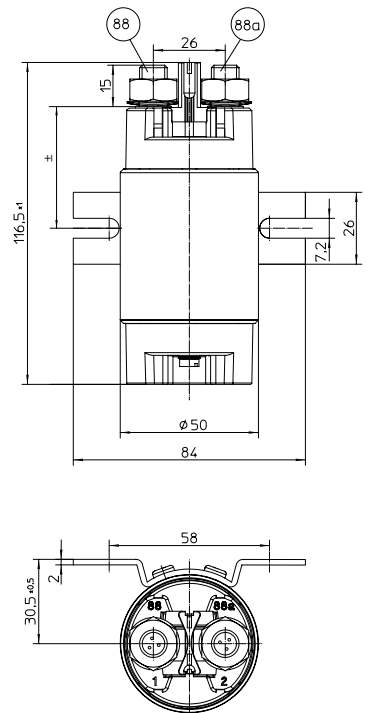

## Options: Magnetic blowouts

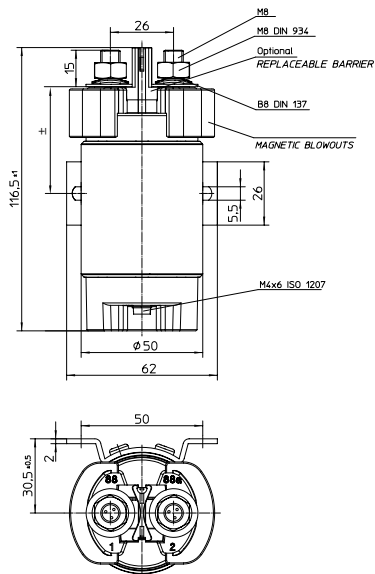

## ORDERING INFORMATION

Part Number  
example: 31-311-12-E  
31 - 3 \_ \_ - 1 \_ - E \_ \_

### Current

3	Current 300 A
---	---------------

### Contacts

1	Make Contact NO
---	-----------------

### Mounting

1	Standard side mounting
2	Short form side
4	Long form side

### Suppression

1	Suppression (integrated)
---	--------------------------

### Options

A	Auxiliary contacts*
B	Magnetic blowout (required over 40 VDC)

\* Not possible for bottom mounting and NO/NC relay

### Coil voltage

1	12 V
2	24 / 28 V
3	36 V
4	48 V
5	60 V
6	80 V

### Suppression

0	Without suppression
1	With suppression

## ACCESSORIES

### Replaceable barrier

29-200-55

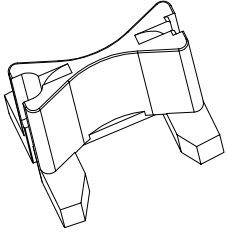

[te.com/KISSLING](https://www.te.com/KISSLING)

© 2023 TE Connectivity. All rights reserved.

KISSLING, TE, TE Connectivity, and TE connectivity (logo) are trademarks owned or licensed by the TE Connectivity Ltd. family of companies. Other logos, product(s) and/or company names might be trademarks of their respective owners.

TE Connectivity's (TE's) only obligations are those stated in TE's General Terms and Conditions of Business ([www.te.com/aboutus/tandc.asp](https://www.te.com/aboutus/tandc.asp)). While TE has made every reasonable effort to ensure the accuracy of the information in this catalog, TE does not guarantee that it is error-free, nor does TE make any other representation, warranty or guarantee that the information is accurate, correct, reliable or current. TE reserves the right to make any adjustments to the information contained herein at any time without notice. TE expressly disclaims all implied warranties regarding the information contained herein, including, but not limited to, any implied warranties of merchantability or fitness for a particular purpose. The specifications in this catalog are for reference purposes only and are subject to change without notice. Consult TE for the latest dimensions and design specifications.

K1166718 | Version 11/2023